

Aluminium Wall Coping

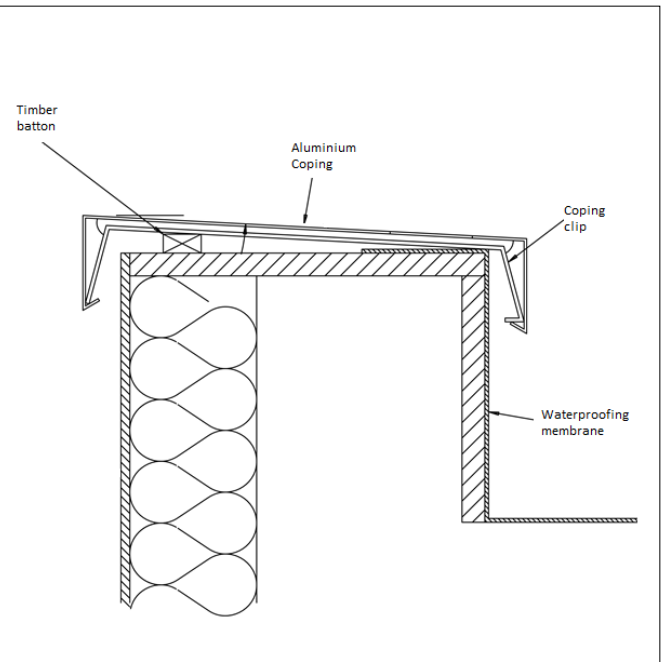
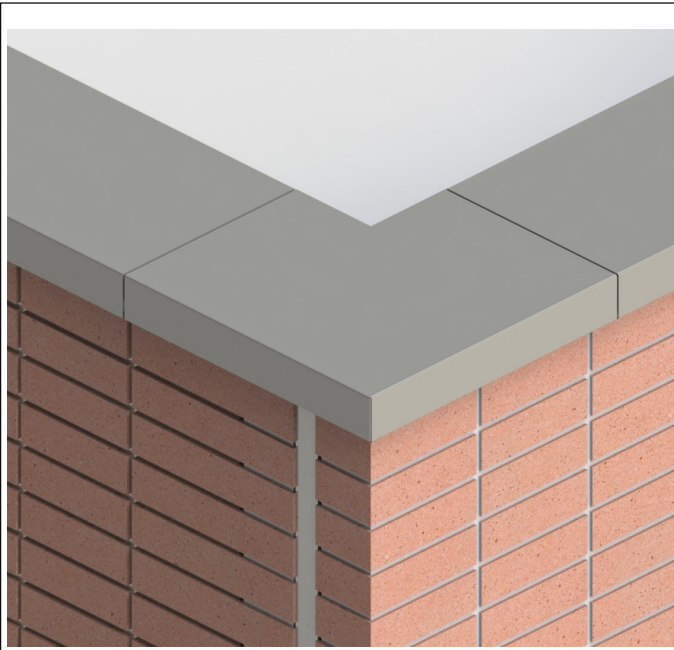

Product Description

Aluminium copings have become the widely accepted alternative to stone copings and are now a first choice owing to their lightweight, corrosion resistant, low maintenance and aesthetically pleasing characteristics.

Properties

Made from 1050AH14 grade aluminium sheet to BS2997 (EN612) with thickness determined by wall width,

Up to 450mm	2mm sheet
450mm +	3mm sheet

Downward pointing legs are manufactured 75mm long with 15mm drip return as standard but alternative dimensions available.

Radius coping - True or faceted radius available. Available Mill Finished (uncoated) or coated on Gutters Online's in-house Polyester Powder Coating line to clients choice of RAL or BS standard colours.

Installation

Please refer to Gutters Online Trueline Coping installation guide for details

Functional Life Expectancy:

The manufacturer qualifies that when installed correctly and maintained in accordance with its product guidelines and O&M procedure, its products are designed to give a minimum effective functional life expectancy of 30 years.

Specification Information

Clause: R10/311 Aluminium Coping

Product: Trueline Aluminium Coping System

Manufacturer:

Handling & Storage:

Copings and other bespoke fabrications, particularly with a polyester powder coat finish should be handled with care and should preferably be stored under cover on racks to prevent scratching. All lengths are supplied in protective polythene wrapping and components are suitably packed in boxes. If painted products are to be stored outside, cover with a tarpaulin to guard against water ingress into the protective polythene. Mill finish items should be stored undercover to avoid uneven oxidation prior to being fitted.

Maintenance:

In order to maintain proper working order, gutters should be periodically cleaned out and any built-up debris removed. Check all fixings are secure and take any remedial action to rectify if necessary. To maximise the life of the decorative paint finishes, all parts should be washed down with clean water at least every 12 months and any damage repaired. In marine/industrial environments, this period may need to be shortened to 6 months.

Further Information

Please visit www.guttersonline.co.uk or contact the Gutters Online team of 0330 912 2288 for any other information